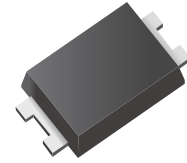


## Thyristor Surge Suppressors (TSS) Data Sheet

### Description

LTP4200AP3 Thyristor solid state protection thyristor protect telecommunications equipment such as modems, line cards, fax machines, and other CPE.

The LTP4200AP3 device is used to enable equipment to meet various regulatory requirements including GR 1089, ITU K.20,K.21 and K.45, IEC 60950, and TIA-968 (formerly known as FCC Part 68).



### Features

- Cannot be damaged by voltage
- Eliminate hysteresis and heat dissipati in typically found with clamping devices
- Eliminate voltage overshoot caused by fast-rising transients
- Are non-degenerative
- Will not fatigue
- Have low capacitance, making them ideal for high-speed transmission equipment
- Meets MSL level 1, per J-STD-020
- Lead free in comply with EU RoHS 2011/65/EU directives

### Ordering Information

Part Number	Marking	Shipping	Reel
LTP4200AP3	420P	12000PCS Tape&Reel	13 inchs

### Thermal Considerations

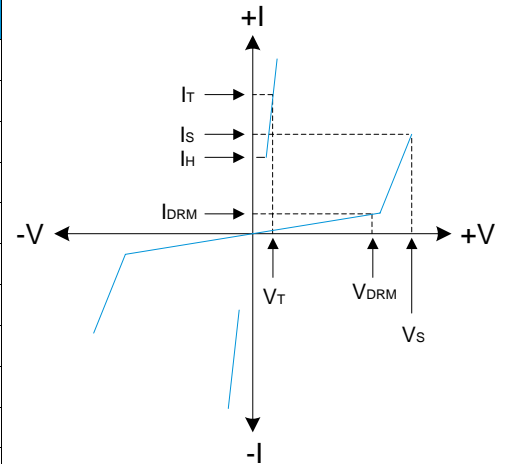
Parameter	Symbol	Value	Unit
Operating Junction Temperature	$T_J$	-40 to +150	°C
Storage Temperature Range	$T_S$	-40 to +150	°C
Junction to Ambient on printed circuit	$R_{\theta JA}$	90	°C/W
Non-repetitive Peak Impulse Current 10/1000 $\mu$ s	$I_{PPSM}$	50	A
Non-repetitive peak impulse Voltage 10/700 $\mu$ s	$V_{PPSM}$	2000	V

### Electrical Characteristics

Part Number	$V_{DRM}$ (V)	$V_S$ (V)	$V_T$ (V)	$I_{DRM}$ ( $\mu$ A)	$I_S$ (mA)	$I_T$ (A)	$I_H$ (mA)	$C_o$ (pF)
LTP4200AP3	400	500	3	2	800	2.2	50	35

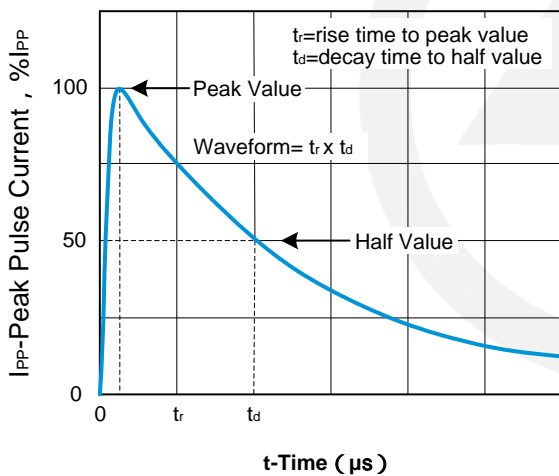
## Electrical Parameters

Parameter	Definition
$V_{DRM}$	<b>Peak Off-state Voltage</b> – maximum voltage that can be applied while maintaining off state
$V_S$	<b>Switching Voltage</b> – maximum voltage prior to switching to on state
$V_T$	<b>On-state Voltage</b> – maximum voltage measured at rated on-state current
$I_{DRM}$	<b>Leakage Current</b> – maximum peak off-state current measured at $V_{DRM}$
$I_S$	<b>Switching Current</b> – maximum current required to switch to on state
$I_T$	<b>On-state Current</b> – maximum rated continuous on-state current
$I_H$	<b>Holding Current</b> – typical current required to maintain on state
$C_O$	<b>Off-state Capacitance</b> – typical capacitance measured in off state
$I_{PP}$	<b>Peak Pulse Current</b> – maximum rated peak impulse current
$I_{RSM}$	<b>Peak One-cycle Surge Current</b> – maximum rated one-cycle AC current
$di/dt$	<b>Rate of Rise of Current</b> – maximum rated value of the acceptable rate of rise in current over time

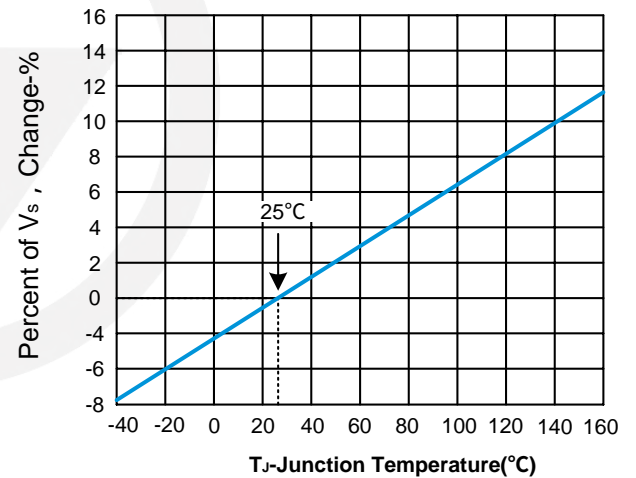


## Characteristics Curves

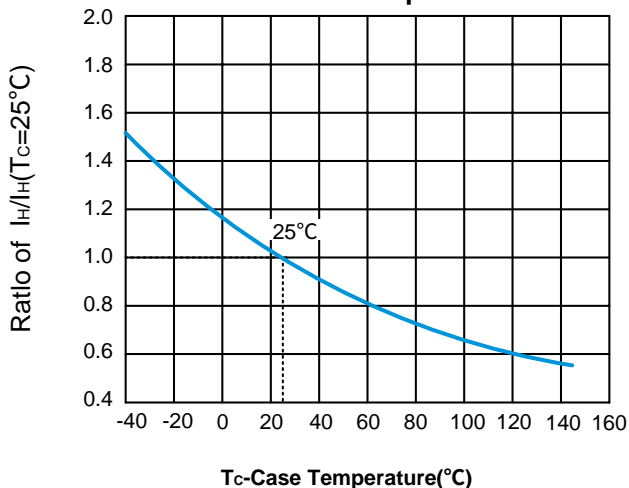
**Fig.1  $t_r \times t_d$  Pulse Wave-form**

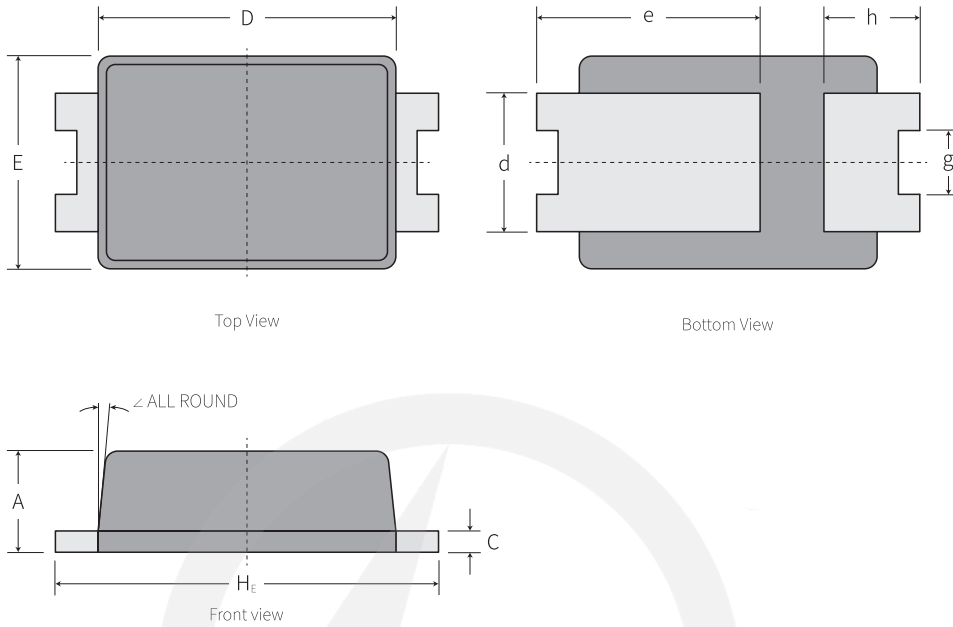


**Fig.2 Normalized  $V_S$  Change versus Junction Temperature**

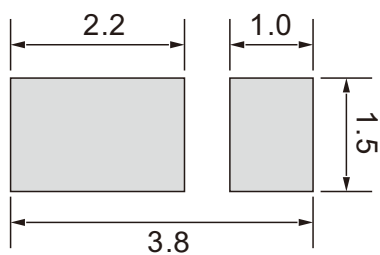


**Fig.3 Normalized DC Holding Current versus Case Temperature**



**Package Outline**
**PDFN3620**
**Unit : mm**


UNIT		A	C	D	E	H <sub>E</sub>	d	e	g	h	∠
mm	max	1.15	0.30	3.00	2.20	3.80	1.50	2.30	0.80	1.10	6°
	min	0.75	0.10	2.60	1.80	3.40	1.10	1.70	0.40	0.70	

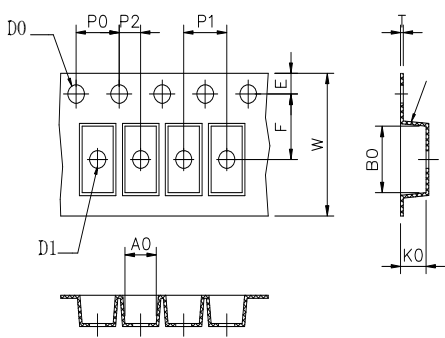
**Suggested Pad Layout**
**PDFN3620**
**Unit : mm**


Note:

1. Controlling dimension: in millimeters.
2. General tolerance:  $\pm 0.05\text{mm}$
3. The pad layout is for reference purpose only.

## Carrier Tape Dimensions

Unit : mm



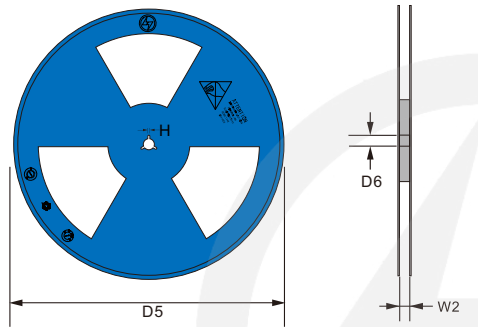
The diagram shows a top view and a side view of the carrier tape. The top view labels dimensions: D0 (pitch), P0, P2, P1 (pitch), E (width), F (width), W (width), D1 (width), A0 (width), and K0 (width). The side view labels dimensions: B0 (height) and K0 (width).

Symbol	Spec	Symbol	Spec
W	8.00±0.10	P1	4.00±0.10
E	1.75±0.10	P2	2.00±0.05
F	3.50±0.05	T	0.22±0.02
D0	1.55±0.05	A0	2.30±0.10
D1	1.50±0.10	B0	3.90±0.10
P0	4.00±0.10	K0	1.15±0.05

## Reel Dimensions

Unit : mm

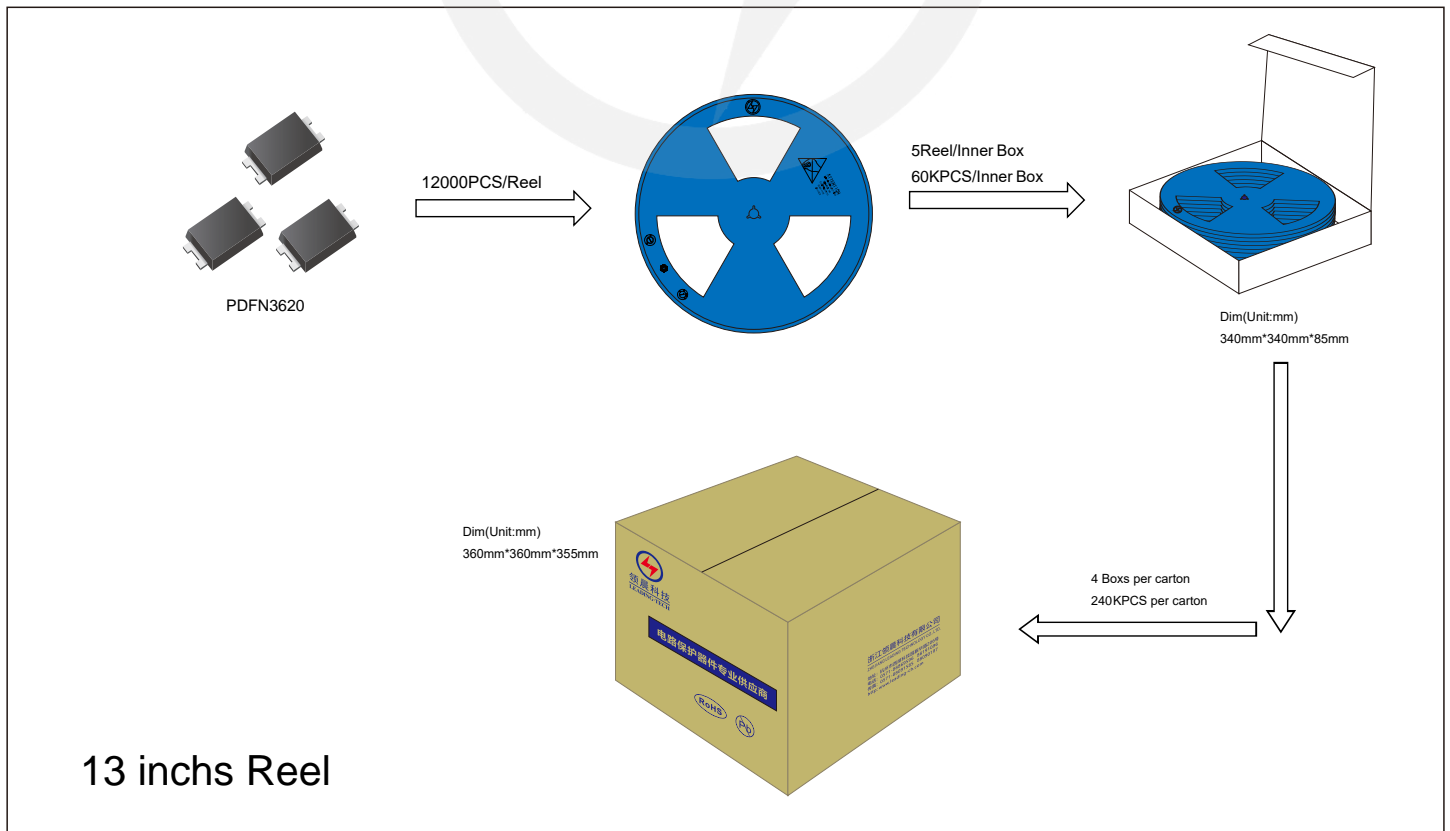
13" Reel



The diagram shows a top view of a 13-inch reel with dimensions D5 (outer diameter), D6 (inner diameter), H (height), and W2 (width). A side view shows the thickness of the tape.

D5	Φ330.0±2.0
D6	Φ13.5±0.5
H	2.5±1.0
W2	12±2.0
Quantity: 12000PCS	

## Packaging





Recommended Soldering Conditions



Recommended Conditions

Profile Feature	Pb-Free Assembly
Average ramp-up rate (T <sub>L</sub> to T <sub>P</sub> )	3°C/second max.
Preheat	
-Temperature Min (T <sub>S min</sub> )	150°C
-Temperature Max (T <sub>S max</sub> )	200°C
-Time (min to max) (t <sub>s</sub> )	60-180 seconds
T <sub>S max</sub> to T <sub>L</sub>	
-Ramp-up Rate	3°C/second max.
Time maintained above:	
-Temperature (T <sub>L</sub> )	217°C
-Time (t <sub>L</sub> )	60-150 seconds
Peak Temperature (T <sub>P</sub> )	260°C
Time within 5°C of actual Peak Temperature (t <sub>p</sub> )	20-40 seconds
Ramp-down Rate	6°C/second max.
Time 25°C to Peak Temperature	8 minutes max.

## Important Notice and Disclaimer

Leading-Tech reserves the right to make changes to this document and its products and specifications at any time without notice.

Customers should obtain and confirm the latest product information and specifications before final design, purchase or use.

Leading-Tech makes no warranty, representation or guarantee regarding the suitability of its products for any particular purpose, not does Leading-Tech assume any liability for application assistance or customer product design.

Leading-tech does not warrant or accept any liability with products which are purchase or used for any unintended or unauthorized application.

No license is granted by implication or otherwise under any intellectual property rights of Leading-Tech.

Leading-Tech products are not authorized for use as critical components in life support devices or systems without express written approval of Leading-tech.

## Version Update Information

Series NO.	Enactment/Revision Date	Effective Date	Version	Revision content	Revision Reason	Revision Person	Note
01	2024.12.20	2024.12.20	1.0	New File	/	Ding	